



Transtank[®]
INTERNATIONAL

Operator's Product HandBook

xTreme[™]

Pressure Cleaning Trailer



“HELPING TO DEVELOP AND PROTECT THE LAND”

Contents

Safety	4
General Safety Instructions	5
General Information	6
Specifications	6
Description	7
Machine Limitations	10
Driving Stability	10
Operating Instructions	11
Before First Use	11
Jetwave Hornet G2 Pump Operation – Petrol and Diesel versions	13
Washown Pump Operation – Petrol Engine	13
Washdown Pump Operation – Diesel Engine Option	14
Filling the Tank	15
xTreme Operation	18
xTreme Plus Operation	18
Risk Assessment	22
Maintenance	23
Periodic Checks	23
Maintenance Schedule	23
Trouble Shooting	27
Warranty	28
Warranty Policy	28
What this Warranty Does Not Cover?	28
How to Obtain Service Under this Warranty?	28
Warranty Limitations	28

Disclaimer

All information, illustrations, and specifications contained in this manual are based on the latest product information available at the time of this publication's printing. TransTank International (TTi) reserves the right to alter and substitute specifications and methods at any time, in line with our commitment to continuous improvement.

No patent liability is assumed with respect to the use of information contained within this manual. While every precaution has been taken in the preparation of this manual, TTi assumes no responsibility for errors or omissions.

Thank you for purchasing an xTreme[™] Pressure Cleaning Trailer (xTreme), which will provide many years of reliable service when operated and maintained in accordance with this manual.

TTi manufacture a range of xTreme and xTreme Plus units, with 1,000 or 2,000 litre tanks respectively, supplied with petrol or diesel pump options. This manual describes the operation, driving stability and maintenance procedures applicable to all units, noting additional requirements to options where necessary.

All TTi xTreme tanks are rotationally moulded from quality polyethylene, purpose designed and manufactured to high standards. The xTreme is a trailer-mounted, heavy duty cold wash pressure cleaning unit, ideal for councils, civil and industrial uses. An optional washdown pump system is available for the xTreme Plus, which can be fitted with optional hydrant fill kit and dual deflector spray head manifold system for dust suppression duties on unmade roads, construction sites, etc.

The xTreme unit is supplied complete, tested and ready to go. TTi recommends that only water be used in the xTreme unit. TTi warrants that the xTreme has been designed and built for its intended purpose for pressure cleaning, with the optional washdown pump system suitable for firefighting and dispensing water, such as tree watering. With the optional deflector system, it can be used as a dust suppression system too.

The owner is responsible to ensure that the equipment is operated in accordance with this manual, with Australian WorkSafe requirements, applicable road rules and local council regulations. TTi is not liable for any loss, injury or death resulting from the failure to observe all safe working regulations as required by law.

Included with your xTreme unit is the following documents:

1. Operator's Handbook (this manual, which includes the Warranty Registration Card)
2. Jetwave Hornet G2 high pressure cleaner unit manufacturer's handbook with integral Honda Petrol GX390 or Kohler Diesel KD15-44 engine (whichever option selected)

For the xTreme Plus variant the following additional documents are included:

3. Davey twin impeller firefighting pump with integral Honda GX200 engine or Yanmar diesel engine (whichever option selected) manufacturer's handbook.

Safety

This manual is intended for use by personnel experienced in the use of this and similar equipment. Read and understand this manual before attempting to operate or perform routine maintenance on this equipment. Your safety is of prime priority.



A WARNING highlights an essential operating or maintenance procedure, practice, condition or statement, which, if not strictly observed, could result in injury or death of personnel, or long-term health hazards.



A CAUTION highlights an essential operating or maintenance procedure, practice, condition or statement, which, if not observed, could result in damage or destruction of equipment.



A NOTE highlights or clarifies an essential systems description, operating or maintenance procedure, condition or statement.

General Safety Instructions

1. This unit is designed and manufactured solely for the purpose of carrying and pumping water for firefighting, tree watering and optional dust suppression duties. Under no circumstances should it be used for any other purpose. It must never be used for transporting fuel or chemicals.
2. Only authorised and trained personnel are to operate this equipment. Operators must have read and fully understood this manual before operating the unit.
3. Do not operate this equipment while under the influence of alcohol or any drugs that could impair your capabilities in any way.
4. Personal Protection Equipment (PPE) must be worn when refueling or operating the pump on the xTreme unit. Exposure to excessive noise over an extended period can cause impairment or loss of hearing.
5. Avoid diesel or unleaded petrol contact with skin and eyes; and avoid breathing vapours or mists. Refer to the relevant Safety Data Sheet (SDS).
6. The engine must be off, and cool before refilling. Any spillage of fuel while refilling the pump engine's tank should be immediately cleaned up and the materials used in the clean-up disposed of safely and in accordance with relevant regulations applying to the safe use, storage and disposal of fuel.
7. Disconnect the battery, if fitted, before conducting any electrical maintenance work.
8. Ensure the capacity of the vehicle is suitable for the loaded mass of the xTreme. Refer to the vehicle's operator manual for safe working loads and relevant safety instructions. Do not exceed the carrying and braking capacity as specified by the vehicle manufacturer.
9. Ensure the tow vehicle is equipped with a 7-pin plug, with the AUX pin wired for 12-volt power. This pin connects to the brake safety unit.
10. The xTreme must never be left unattended while being filled with water.
11. Do not operate the pump when there is no water in the tank.
12. Do not disconnect any hoses, nozzles or filters while the equipment is operating. Disconnecting any components while under pressure may result in uncontrolled water discharge which may be hazardous.
13. Care should be taken at all times, particularly when operating on rough or steep terrain. Drivers should be aware of fluid surge affecting the centre of gravity.
14. The xTreme unit has safety labels affixed to various locations on the trailer. These labels should be kept clean and legible, and replaced if damaged.
15. Any unauthorised modifications to this equipment may affect its function and create a serious safety risk. Any unauthorised modifications will void any warranty on the unit.

General Information

Specifications

Tank	UV resistant polyethylene tank - 1,000 litre for xTreme and 2,000 litres for xTreme Plus, complete with LiquidLocker™ Baffle Safety System
Trailer	Fully welded and galvanised heavy duty steel frame, single axle (xTreme) or dual axle (xTreme Plus) with 15" Sunraysia wheels with 6-stud pattern
Standard Equipment	<p>LiquidLocker™ Baffle Safety System</p> <p>Jetwave Hornet G2 High Pressure Cleaner (4,060 psi / 280 bar, 15L per min) with Honda petrol GX390 engine</p> <p>20m 19mm hose reel with heavy duty braided hose and spray wand</p> <p>Pressure regulator</p> <p>Davey twin impeller pump washdown system with integral Honda GX200 engine (xTreme Plus only)</p> <p>Open funnel for stand pipe fill</p> <p>Tank bottom fill kit via integral washdown pump (xTreme Plus only)</p> <p>Quick fill hose kit (xTreme Plus only)</p> <p>Hydraulic (xTreme) or electric brakes (xTreme Plus only)</p>
Options	<p>Kohler diesel KD15-44 engine option for Jetwave Hornet G2 High Pressure Cleaner (3,150 psi / 210 bar, 15L per min)</p> <p>Yanmar diesel engine option for Davey twin impeller pump washdown system</p> <p>Electric start on engines (with solenoid operated deflector option) for washdown pump system</p> <p>Dual deflector spray head manifold system (xTreme Plus only)</p> <p>Solenoid operation of dual deflector spray head manifold system (xTreme Plus only)</p> <p>Detergent Injection System</p> <p>Sight level tube</p> <p>Hydrant fill system (xTreme Plus only)</p> <p>20m 19mm spring rewind hose reel (for washdown pump system)</p>

Description

The TTi xTreme™ is designed to carry and distribute water using a self-contained high pressure cleaning unit, with the xTreme Plus fitted with a washdown system and optional dual deflector spray head manifold system. The xTreme has the following features, refer to Figure 1, with the xTreme Plus shown in Figure 2



Figure 1 – Component Identification - Front



Figure 2 – Component Identification - Rear

Tank

All TTI tanks are constructed from UV resistant, virgin material polyethylene. Due to the rotational moulding process, there may be a small variance in the overall dimensions of the tank, therefore, calibration markings should be used as a guide only.

LiquidLocker Safety Baffle System

The LiquidLocker baffle system within the tank demonstrates measurable improvements in braking performance and dynamic stability and controllability. The system has been independently tested, with the report available upon request.

Tank Level Indicator

An optional sight level tube is fitted to the rear of the tank and provides an accurate level indication of water within the tank.

Pressure Cleaner Unit

Jetwave Hornet G2 Pressure Cleaner fitted with a Honda petrol GX390 engine or optional Kohler diesel KD15-44 engine. Both engines are equipped with electric start via an integrally mounted 12V battery. The unit is fitted with an unloader valve (regulator), allowing adjustment of water pressure through the spray wand. The unit is supplied with an emergency stop pushbutton.

Detergent Injection System

An optionally available 10 litre detergent tank is mounted next to the Jetwave unit. A hose from the tank's sump connects directly to the pressure cleaner's outlet line, drawing detergent via a venturi effect into the hose.

Washdown Pump System

The xTreme Plus is fitted with a twin impeller Davey firefighting pump as standard. The pump is coupled to a Honda GX200 engine or optional Yanmar diesel engine. The petrol engine is recoil (pull) start with local or remote electric start upgrade options available. The diesel engine is electric start with a remote start option available.

Pressure Regulator

A pressure regulator is fitted to the washdown pump discharge flange to control line pressure and prevent pump cavitation. The factory-set regulator feeds excess water back to the tank and is set to relieve at 50 – 60 psi.

Hose Reels

Each xTreme is fitted with a 20m 19mm diameter heavy duty, braided hose mounted on a manually operated hose reel for the pressure cleaner unit. The attached trigger operated spray wand locates in a securing bracket either behind the pressure cleaner unit or next to the tank, for stowage.

The washdown pump system on the xTreme Plus unit includes a 36m 19mm diameter hose on a manually operated hose reel. The hose is fitted with an adjustable nozzle which locates in a securing bracket on the hose reel support when the hose is stowed. The nozzle adjusts from closed through to jet and mist sprays, depending on requirement.

A spring rewind 20m hose reel is available as an option for the washdown pump system.

Batteries

The Jetwave Hornet G2 High Pressure Cleaning unit comes with its own integrated battery for starting the standard petrol or optional diesel engines.

With electric brakes installed on the xTreme Plus trailer, a dedicated 12-volt battery is mounted at the front of the tank, housed in a battery box.

With the optioned electric pump start upgrade on the washdown system (xTreme Plus only), a separate, dedicated 12-volt battery is installed behind the hose reel. Power to start the pump is always provided by this battery.

Quick Fill Hose Kit

Each xTreme Plus is fitted with a side-mounted hose bracket, housing the 6m quick fill hose. The hose is fitted with a filter at one end and a camlock coupling on the opposite end, for direct connection to the washdown system pump.

Hydrant Fill Kit

An optional hydrant fill kit is available for the xTreme Plus, which feeds directly into the top of the tank, with a camlock coupling to directly connect to a hydrant hose.

Trailer

The trailer frame is an all steel, fully welded construction and hot dip galvanised for corrosion resistance. The frame has additional welded gussets for added strength and filled-in chequer plate mudguards to protect the tank. Single axle (xTreme) and dual 50mm solid axle (xTreme Plus) are fitted with 6-stud 15' Sunraysia wheels.

The single axle xTreme trailer is fitted with a hydraulic braking system. The xTreme Plus dual axle trailer is fitted with electric brakes, complete with its own dedicated 12-volt battery located at the front of the trailer, and incorporates a break-away safety system, refer to Figure 4. Both trailer types include a jockey wheel for ease of coupling to the tow vehicle.

Deflector Spray Heads

An optional dual deflector spray head manifold is available on the xTreme Plus. Each deflector spray head is fitted with its own dedicated ball valve for individual operation. An optional solenoid actuated valve enables the dual water deflector spray head system to be activated via the remote control unit.

Each of the dual deflectors are mounted on a hot dip galvanised steel manifold fed directly from the washdown pump's outlet manifold via a high pressure flexible hose, which absorbs vibration from the pump.

Each deflector spray head is secured with a camlock fitting, allowing removal for cleaning and adjustment for water spray direction.

Ball Control Valves

The xTreme variants have several ball control valves (depending on options) used to open or close water flow from the washdown pump to the discharge points (hose reel and optional deflector spray head system). Ball control valves are also fitted on the suction line and the discharge side of the tank prior to entering the pressure cleaning pump (both variants) and the washdown pump (xTreme Plus).

Solenoid Valve

An optional electrically operated solenoid valve is fitted to the deflector manifold to enable spray control via the remote control unit. The solenoid valve receives its power from the tow vehicle via the Anderson plug located adjacent to the tow hitch. Where the xTreme Plus's washdown system is fitted with the electric start option, the solenoid valve may be operated by selecting the SELF POWERED position on the three-way switch of the control box mounted at the rear of the xTreme Plus trailer. This should only be used where power is not available via the Anderson plug from the tow vehicle.

Remote Control Unit

An optional remote control unit enables the operator to start the xTreme Plus's optional dual water deflector spray system while in the tow vehicle's cab. If the optional petrol or diesel pump with electric start is fitted, the remote control unit enables pump start and stop, in addition to the water deflector spray system operation.

Machine Limitations

The xTreme units are subject to operating limitations. It is the operators' responsibility to ensure that this equipment is being operated safely and within these limitations.

Driving Stability

The xTreme unit is heavy when filled with water. To maintain stability while operating this unit:

- Ensure the trailer tyres are inflated to their correct pressure at all times. Underinflated tyres can cause excessive lateral motion of the tyre, which may cause a rollover.
- Allow extra room for braking and turning when the tank is full.
- Ensure any side gradient (slope) is accounted for, especially when the xTreme tank is full, as the unit will have a higher centre of gravity.
- Ensure the reversing brake lockout latch (for the hydraulic braked xTreme variant only, refer to Figure 3) is disengaged prior to towing the xTreme unit in a forward direction.

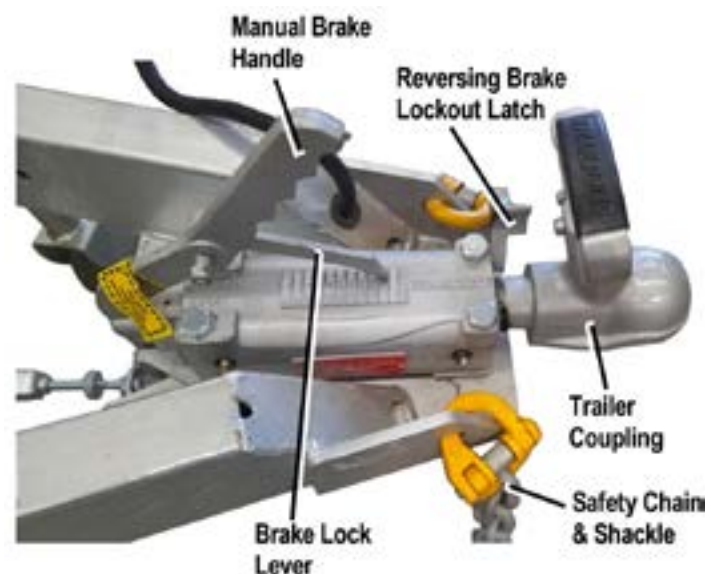

Figure 3 – Coupling Brake Unit – xTreme variant

Operating Instructions

Before first use

Your xTreme Pressure Cleaning Trailer is delivered fully assembled. Before use, it needs to be set up using the following instructions:

1. Complete the warranty registration online at www.tti.com.au/warranty-registration, or use the Warranty Registration Card at the back of this handbook.
2. Store this handbook, along with the Jetwave Hornet G2 High Pressure Cleaner unit and associated manuals in a safe and easily accessible place for future reference.



WARNING: The operator must fully understand all aspects of this handbook. Do not operate the xTreme unit if you are unfamiliar with its operation until you have read this handbook.

3. Read and thoroughly understand this handbook, paying particular attention to all safety requirements, before using the xTreme for the first time.
4. Check that all fittings, valves, hoses and electrical leads are secure following transit, and are not damaged in any way.
5. Inspect the tank for any damage or abrasions.
6. Connect the xTreme to the tow vehicle, ensuring the tow hitch engages correctly and locks in place. Connect the safety chains using rated D-shackles.
7. Connect the 7-pin trailer plug to the tow vehicle, ensuring it locks firmly. Ensure the AUX pin is supplied with 12-volt power from the tow vehicle, as this is essential for the electric brake safety unit (fitted to the xTreme Plus trailer), refer to Figure 4. Check lights and indicators operate correctly.
8. If fitted, connect the xTreme's Anderson plug socket to the tow vehicle for power supply to the optional solenoid operated ball valve, refer to Figure 4.

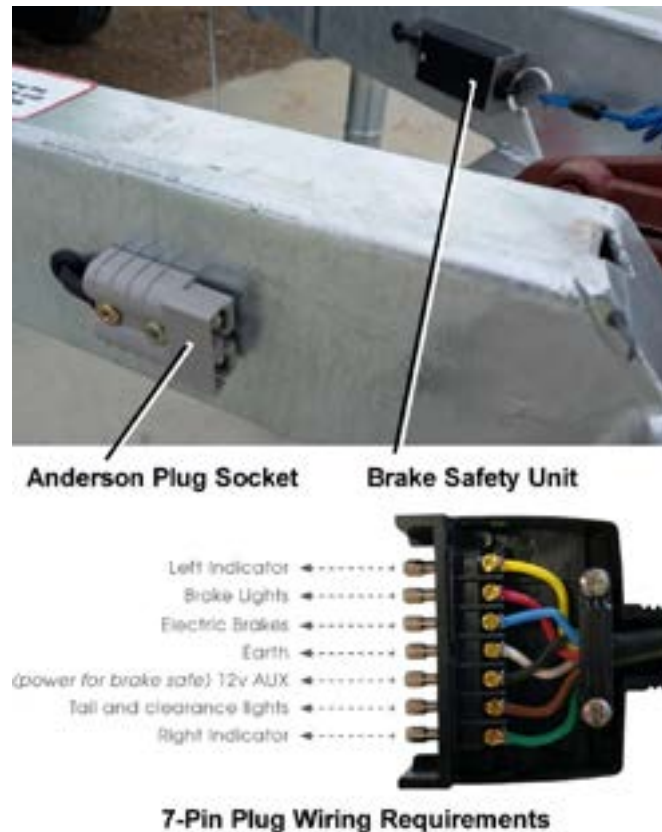

Figure 3 – Coupling Brake Unit – xTreme variant



WARNING: The engine must be inspected and prepared in accordance with the manufacturer. Failure to fulfil this requirement may void the engine's warranty.

9. Prepare the pressure cleaning unit's engine in accordance with the selected engine's manual supplied with your xTreme unit.
10. For the xTreme Plus, prepare the washdown pump unit's engine in accordance with the selected engine's manual supplied. Inspect the tank for any damage or abrasions.
11. Ensure the 12-volt battery is fully charged and correctly connected to the pressure cleaning pump unit's engine. The battery box is located within the Jetwave Hornet G2 High Pressure Cleaner module.
12. Refer to the Jetwave Hornet G2 unit's manual and prepare the engine for use, such as filling its tank with fuel.
13. Where an electric start petrol or diesel engine is optioned for the washdown system (xTreme Plus only), ensure the 12-volt battery is fully charged and correctly connected to the pump unit's engine. The battery box is located behind the hose reel. Refer to the supplied pump unit's manual and prepare the engine for use, such as filling its tank with fuel.

Jetwave Hornet G2 Pump Operation – Petrol and Diesel versions

The pressure cleaning unit pump is started up as follows:

1. For operation of the pressure cleaning unit, refer to the supplied Jetwave Hornet G2 manual, including the relevant Honda petrol GX390 engine or optional Kohler diesel KD15-44 engine manuals.
2. Fill the tank with water as described in the Filling the Tank section below.

Washown Pump Operation – Petrol Engine

The xTreme Plus's washdown petrol pump engine is started as follows, refer to Figure 5:

1. Turn the fuel lever to ON.
2. If the engine is cold, turn the choke lever to ON.



CAUTION: Ensure the engine's throttle is set to idle if the engine is cold. Do not adjust the throttle to maximum speed until the engine has warmed up.

3. Set the throttle lever to idle for cold starting. If restarting a warm engine, the throttle can be left at normal engine operating speed.
4. For a manual start engine, turn the power switch to ON. Pull the recoil starter handle until the engine starts, then back off the choke lever to OFF.

For an optional electric start engine, insert the key and switch the engine to ON and START. When the engine starts, release the key, which will return to the ON position. Back off the choke lever to OFF.

For an optional electric start engine using the remote control, insert the key and switch the engine to ON. Press and hold the No. 1 button of the remote control unit for several seconds. When the engine starts, release the pushbutton and back off the choke lever to OFF.

5. Once the engine is warmed up, adjust the throttle to increase the engine speed to normal operating revs.
6. 6. When the engine needs to be stopped, turn the power (manual start) or key switch (electric start) to the OFF position. For the remote control option, press the No. 2 button.

If the xTreme Plus is not going to be used within the next few hours, shut the system down by turning the fuel tap to OFF.



Figure 5 – Engine Start-up (Petrol Engine shown)

Washdown Pump Operation – Diesel Engine Option

The xTreme Plus's optional diesel pump engine is started as follows, refer to Figure 5:

1. Turn the fuel lever to ON.



CAUTION: Ensure the engine's throttle is set to the start position. Do not adjust the throttle to maximum speed until the engine has warmed up.

2. Set the throttle lever to the START or RUN position (depending on model).
3. Insert the key and switch the engine to ON and START. When the engine starts, release the key, which will return to the ON position.

For the optional remote control electric start engine, press the No. 1 button of the remote control unit to turn the ignition ON, then press and hold No. 2 button for several seconds. When the engine starts, release the pushbutton.

4. Once warmed up, adjust the engine speed to normal operating revs using the throttle lever.
5. When the engine needs to be stopped, turn the throttle lever back to the idle position.
6. Turn the key switch to the OFF position. For the remote control option, press the No. 1 button to turn the ignition OFF.

If the xTreme Plus is not going to be used within the next few hours, shut the system down by turning the fuel tap to OFF.

Filling the Tank

The tank of the xTreme pressure cleaning unit variants may be filled in any of the following three ways:



CAUTION: The xTreme unit is designed for water use only. It must not be used for chemicals or fuel.

1. Standpipe filling method using a standpipe to fill directly into the top of the tank via the open mesh funnel.
2. Optional bottom filling method (xTreme Plus only), using the washdown pump to draw water from a dam or other source.
3. Optional hydrant filling method (xTreme Plus only), drawing pressurised water directly from a hydrant via the filling hose.

Standpipe Filling Operation

The xTreme tank is filled by gravity from an overhead standpipe as follows:

1. Position the xTreme unit's top-mounted fill point funnel under the standpipe.
2. Remove the filling lid from the tank's top opening.
3. Open the standpipe's valve and allow water to flow into the tank.



CAUTION: To prevent overflow, do not leave the filling operation unattended.

4. An optional sight level tube is fitted to the rear of the tank, providing a visual indicator of the level of water in the tank. If a sight level tube is not fitted, observe the water level directly in the tank. When the tank is filled, close the standpipe's valve.
5. Upon completion of filling, replace the tank's filling lid.

Bottom Filling Operation (xTreme Plus)

The tank is filled by drawing water using the xTreme Plus's washdown pump as follows, referring to Figure 6:



CAUTION: Ensure all ball valves have been correctly set prior to commencing the filling operation, and that all camlock fittings are securely engaged and fully locked.

1. Ensure the ball valve on the suction line from the bottom of the tank to the pump is closed.
2. Remove the camlock cap from the discharge port of the pump.
3. Release the camlock fittings and disconnect the suction line from the pump, then connect it to the pump's discharge manifold port above.
4. A bottom fill supply hose is located on its bracket at the side of the xTreme's trailer. Remove it from the bracket and attach the camlock end to the pump's suction port.
5. Place the filter end of the bottom fill hose into the water source. Ensure the filter is deep enough in the water to prevent it sucking air.
6. Open the ball valve on the suction line from the bottom of the tank – this line is now connected to the pump's discharge port.
7. If required, prime the pump by unscrewing the cap at the top of the pump and fill it with water. Once full, replace the cap and tighten firmly.
8. Referring to Pump Operation procedures (diesel or petrol engine), start the pump.
9. Ensure the pump is drawing water and discharging it into the xTreme's tank.



CAUTION: To prevent overflow, do not leave the filling operation unattended.

10. An optional sight level tube is fitted to the rear of the tank, providing a visual indicator of the level of water in the tank. If a sight level tube is not fitted, observe the water level directly in the tank. When the tank is filled, stop the pump.
11. Close the ball valve on the line to the bottom of the tank.
12. Disconnect the bottom fill supply hose from the pump's suction port.
13. Disconnect the tank's suction line from the pump's discharge port and reconnect it to the pump's suction port.
14. Reinstall the camlock cap to the pumps' discharge manifold.
15. Open the tank valve.
16. Drain and clean the hose and return it to its stowage bracket at the side of the trailer.

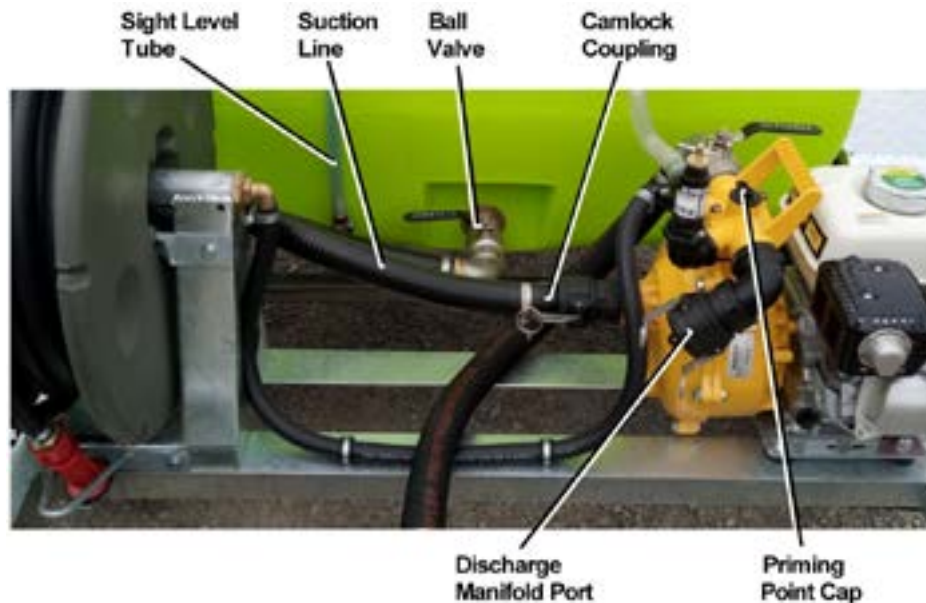

Figure 6 – Tank Filling Operation

Hydrant Filling Operation

The xTreme Plus tank is filled from a hydrant via the optional hydrant fill system as follows, referring to Figure 7:

1. Attach one end of a 3" hydrant hose (not supplied) to the xTreme Plus's hydrant port, the other end to the hydrant.
2. Remove the tank's filling lid from the top of the tank.
3. Open the supply hydrant's valve slowly; water will flow under pressure through the xTreme's pipe system into the top of the tank.



CAUTION: To prevent overflow, do not leave the filling operation unattended.

4. An optional sight level tube is fitted to the rear of the tank, providing a visual indicator of the level of water in the tank. When the tank is filled, close the supply hydrant's valve.
5. Replace the filling lid.
6. Disconnect the hydrant supply hose and stow it.



Figure 7 – Hydrant Filling Operation (optional fill kit)

xTreme™ Operation

Initial Operation Set Up

The xTreme Pressure Cleaning Unit variant is operated as follows:

1. Connect the unit to the tow vehicle and check security of all connections (refer to Before First Use procedure above).
2. Fill the tank from an appropriate water source, refer to the Filling the Tank procedure above.
3. For the Jetwave Hornet G2 pressure cleaning unit, open the ball valve on the suction hose at the bottom of the tank.
4. Start the Jetwave pump (referring to the procedure above) and allow to warm up. The regulator (bypass valve) fitted to the pump will divert the water back into the tank.

xTreme Plus Operation

Initial Operation Set Up

The xTreme Plus Pressure Cleaning Unit variant is set up and operated in the same manner as the xTreme variant described above.

Washdown unit Operation

The xTreme Plus washdown unit is operated as follows:

1. Connect the unit to the tow vehicle and check security of all connections (refer to Before First Use procedure above).
2. Fill the tank from an appropriate water source, refer to the Filling the Tank procedure above.
3. For the washdown unit, open the ball valve on the suction hose at the bottom of the tank.
4. Start the washdown pump (referring to the Washdown Pump Operation procedure above) and allow to warm up. The regulator (bypass valve) fitted to the pump will divert the water back into the tank.

Washdown Hose Use

With the xTreme Plus washdown unit operating as described above, the washdown hose is used as follows, refer to Figure 8:

1. Unlock the hose reel and release the hose's nozzle from its retaining bracket. Pull out the length of hose required.
2. Adjust the pump engine's speed to achieve the optimum flow rate.
3. Open the hose's nozzle by rotating it to achieve the desired spray pattern.
4. Upon completion of the task, close the hose nozzle and turn the pump engine to OFF, referring to the appropriate Washdown Pump Operation procedure above.
5. Open the hose nozzle again to release the residual pressure.
6. Rewind the hose onto the reel by manually winding the handle on the side of the reel. Close the nozzle and lock the nozzle back into its bracket.
7. Close the ball valve on the suction hose at the bottom of the tank.



Figure 8 – Washdown Hose Reel

Water Deflector Spray Head

The xTreme Plus can be optionally fitted with a dual deflector spray head system mounted across the back of the unit. The system has a deflector spray head located at each corner. These systems may be used for dust suppression or similar watering activities.



CAUTION: The solenoid is electrically active when in use. Ensure it is switched to the POWERED position at the three-way switch.

If fitted with the optional solenoid actuated valve, move the three-way switch at the rear of the xTreme Plus trailer from OFF to the POWERED position, refer to Figure 9. This will draw power from the tow vehicle via the Anderson plug. If power is not available, move the switch to the SELF POWERED position. This will draw power from the pump engine's battery. Using this battery should only be for short periods as the battery has limited charging capacity.



Figure 9 – Solenoid Control Switch

The optional dual deflector spray head system is operated as follows:

1. If required, release the camlock connector to rotate the deflector spray head to the desired angle, refer to Figure 10. Lock the spray head back into place, ensuring the camlock levers are fully home.
2. Start the xTreme Plus's washdown pump system as described above.
3. At each deflector spray head, open the ball valve. Water will spray from the deflector.

Where the optional solenoid actuated valve is fitted, press button No.3 on the remote control. Water will spray from the deflector/s.

4. Commence driving the tow vehicle at a moderate speed to achieve the required water coverage.
5. For the solenoid actuated valve, press button No. 3 on the remote control to close the valve.
6. Upon completion, stop the vehicle and shut the pump down.

7. Close each of the deflector spray head's ball valves.
8. Close the ball valve on the suction hose at the bottom of the tank.
9. For the solenoid actuated valve option, move the three-way switch to the OFF position.



Figure 10 – Water Deflector Spray Head (optional)

Risk Assessment

Task	Hazard	Risk	Control Measure/Mitigation
Partially fill the tank with water, start the motor & test the pressure cleaning unit and the optional washdown unit	Manual handling; slips, trips or falls; petrol; diesel; fumes; fingers jammed	Medium	<p>Concentrate on task; follow safe manual handling techniques:</p> <ul style="list-style-type: none"> • Don't lift on your own if > 20kg, bend knees & keep back straight; Keep fingers clear; • Keep unit at least 8m away from overhead powerlines; • Fire extinguisher nearby; • Follow warning stickers on tanks; Wear PPE for petrol & diesel fumes-mask & gloves.
Check weather conditions	Manual handling; slips, trips or falls	Low	<ul style="list-style-type: none"> • Follow safe manual handling techniques: don't lift on your own if >20kg, bend knees & keep back straight.
Use spray or fire fighter units.	As above; loss of load; heat & cold; noise; exceed load limit of vehicle; hose entanglement; exhaust fumes; terrain & slopes; run over by unit	High	<p>As above</p> <ul style="list-style-type: none"> • Wear clothes to suit heat & cold; • Wear hearing protection if noise >85 dBa; • Follow the manufacturer's safe operation instruction for the vehicle and the spray unit • Don't overload - water weighs 1kg for every 1 litre • Secure unit to tow vehicle; • Keep hose tidy; • Put unit brakes on.
Clean up, maintenance & storage	As above	Low	<p>As above;</p> <ul style="list-style-type: none"> • Wear PPE for clean up; • Store unit in a dry, well ventilated area.
Burn risk	Hot exhaust/muffler	Med	<ul style="list-style-type: none"> • Do not reach over hot exhaust • Do not service engine while hot • Wear appropriate PPE

Maintenance

Your xTreme or xTreme Plus Pressure Cleaning Trailer requires minimal maintenance but regular cleaning and checks will ensure safe and reliable service over its lifetime. Periodic checks and inspections will identify any potential issues, enabling timely rectification and minimising downtime.

Periodic Checks



CAUTION! In dusty, dirty or smoky environments, cleaning, inspection and servicing of the unit on a regular basis is essential. The cleaning, inspection and servicing must be undertaken more frequently in harsh conditions to avoid damage or destruction of equipment.

The following checks and cleaning operations should be undertaken on a regular basis. The frequency of these activities will depend on the nature of the operating environment and the operational hours of the xTreme unit. Refer to the maintenance schedule tables below for details of maintenance intervals.

1. Clean the unit and inspect it for any signs of damage or wear. Replace any safety labels if they are damaged or illegible.
2. Check all hoses, fasteners and fittings are firmly secured, tighten if necessary.
3. Unwind the hose from the reel fully to check that hose is in good order. Pressurise the line and check operation of spray nozzle. Rewind the hose onto the reel, ensuring it retracts all the way.
4. For the petrol or optional diesel engine driven pump, check the engine's oil level weekly. Top up as required.
5. Check for any signs of fuel or oil leaks. If detected, investigate and rectify immediately.
6. Check the condition of the Jetwave Hornet G2 pump engine's 12 volt battery, replace it or charge it as necessary.
7. For the washdown system (xTreme Plus) check the condition of the optional diesel or petrol pump engine's 12 volt battery, replace it or charge it as necessary.
8. Check the condition of the xTreme Plus's electrical brakes 12 volt battery, replace it or charge it as necessary.
9. If the xTreme unit is to be stored for an extended period, ensure the tank and all pipelines are empty and are not pressurised. Store the unit in a clean, dry and well-ventilated area.

Maintenance Schedule

The following tasks are to be conducted in accordance with each of the schedules. All scheduled tasks are to be undertaken concurrently. For example, at the three month maintenance interval, all tasks listed are to be undertaken, in addition to the daily, weekly and monthly tasks.



NOTE! Maintenance is important. Keep a record of all maintenance tasks conducted on the xTreme unit.

TTi recommends photocopying these schedules in order to keep a detailed log of all maintenance tasks. A copy of these schedules will be required to support any warranty claim.

Daily Tasks

The following tasks are to be undertaken daily, or prior to each use, of the xTreme or xTreme Plus unit.

No.	Task	Notes
1	Inspect the xTreme unit for any signs of damage or wear	Clean, repair or replace
2	Check trailer plug connections and test lights/indicators	Test function of lights and trailer brakes
3	Check fuel (Pressure Cleaner and Washdown System)	Top up as required
4	Inspect engine(s) air filter and housing for dust	Clean, replace as necessary
5	Press button on brake safety unit (Figure 4) to test charge	Charge brake battery

Weekly Tasks

The following tasks are to be undertaken each week or 10 operating hours, whichever occurs first.

No.	Task	Date	Signed
1	All Daily tasks		
2	Remove and clean the engine(s) air filter		
3	Check engine(s) oil level, top up as required		

Monthly Tasks

The following tasks are to be undertaken each month or 20 operating hours, whichever occurs first.

No.	Task	Date	Signed
1	All Daily and Weekly tasks		
2	Check tyre pressures are 36psi (248kPa or 2.48 Bar)		
3	Visually inspect tyres for wear or damage		
4	Check wheel nut tension		
5	Visually inspect suspension components		
6	Visually inspect hydraulic brake lines, check for leaks, top up reservoir as required		
7	Check for damaged electrical brake cables		
8	Check hose and hose reel by unwinding fully		
9	* Change pump(s) engine oil (and filter, if fitted) (first change, thereafter every six months or 100 operating hours)		

Three Monthly tasks

The following tasks are to be undertaken every three months or 50 operating hours, whichever occurs first.

No.	Task	Date	Signed
1	All Daily, Weekly and Monthly tasks		
2	* Re-tension axle U-bolts (first time, thereafter every six months or 100 operating hours)		
3	Inspect, clean and grease suspension lubrication points		
4	Inspect the air filter(s), replace if clogged or damaged		
5	Check all hoses, fasteners, nozzles and fittings		

Six Monthly tasks

The following tasks are to be undertaken every six months or 100 operating hours, whichever occurs first.

No.	Task	Date	Signed
1	All Daily, Weekly, Monthly and 3-Monthly tasks		
2	Change engine(s) oil (and filter, if fitted)		
3	Inspect spark plug (petrol engine(s) only)		
4	Check tension on axle U-bolts and suspension components		
5	Lubricate grease nipples on suspension shackles and trailer hitch (hydraulic brake version)		

Twelve Monthly tasks

The following tasks are to be undertaken every twelve months or 200 operating hours, whichever occurs first.

No.	Task	Date	Signed
1	All Daily, Weekly, Monthly, 3-Monthly & 6-Monthly tasks		
2	Check the battery condition (Jetwave Hornet G2)		
3	Check the battery condition (xTreme Plus) of brake unit and optional electric start washdown unit		
4	Replace the engine(s) air filter		
5	Drain and flush the fuel tank(s)		
6	Replace the engine(s) fuel filter		
7	Replace the spark plug (petrol engine(s) only)		
8	Inspect brake shoe/pad wear and adjustment		

Two-Yearly tasks

The following tasks are to be undertaken every 24 months or 500 operating hours, whichever occurs first.

No.	Task	Date	Signed
1	All Daily, Weekly, Monthly, 3-Monthly, 6-Monthly and 12-Monthly tasks		
2	Disassembly, clean and repack wheel bearings		
3	Change brake fluid and bleed brakes (hydraulic braked version)		

Troubleshooting

If a fault develops with the xTreme Pressure Cleaning Trailer, the following trouble shooting table provides guidance to identify and rectify the problem.

Problem	Possible cause	Remedy
Pump(s) will not feed water	Ball valve closed on outlet/s	Open ball valve/s
Engine will not crank (petrol or optional diesel engine)	Flat battery	Check battery state-of-charge
	Melted fusible link/circuit breaker	Replace fusible link/breaker
	Loose Connections	Clean and tighten connections
	Faulty Ignition Switch	Check switch operation, replace as needed
	Faulty magnetic, relay, neutral start or clutch switches	Check and replace as needed
	Mechanical problem in engine	Check engine
	Problem in theft deterrent system	Check service manual for system tests
Engine cranks too slowly to start	Weak Battery	Check battery and charge as needed
	Loose or corroded connections	Clean and tighten connections
	Faulty starter motor	Test starter
	Mechanical problems with engine or starter	Check engine and starter, replace worn out parts
Starter keeps running	Damaged pinion or ring gear	Check gears for wear or damage
	Faulty plunger in magnetic switch	Test starter pull-in and hold-in coils
	Faulty ignition switch or control circuit	Check switch and circuit components
	Binding ignition key	Check key for damage
Starter spins, but engine will not crank	Faulty over-running clutch	Check over-running clutch for proper operation
	Damaged or worn pinion gear or ring gear	Check gears for damage and wear; replace as needed
Starter does not engage/disengage properly	Faulty magnetic switch	Bench test starter
	Damaged or worn pinion gear or ring gear	Check gears for damage and wear; replace as needed

Warranty

Warranty Policy

TTI will, at its option, repair or replace without charge any part covered by this warranty which is found to be defective in material and/or workmanship within one (1) year after date of sale to the original retail purchaser. If the product is used for rental purposes, this warranty is limited to ninety (90) days.

Upon request, the customer will make the defective part available for inspection and/or return the defective part to TTI, transportation charges prepaid. All parts and components are covered by this warranty except the following, which are warranted separately by their respective manufacturers:

- engines
- gearboxes
- pumps
- regulators

TTi does not assume any warranty obligation, liability or modification for these items, which are covered exclusively by the stated warranty of the respective manufacturers.

What this Warranty Does Not Cover?

This warranty does not cover:

1. defects caused by depreciation or damage caused by incorrect mounting, normal wear, accidents, improper maintenance, improper use or abuse of the product, alterations or failure to follow the instructions and warnings provided.
2. Any charges for making service calls, clean up time and transport charges.
3. The use of non-genuine parts on equipment supplied by TTI. This will automatically negate any warranty.

How to Obtain Service Under this Warranty?

Warranty service can be arranged by contacting your dealer, or by contacting TTI directly on 1800 816 277.

Proof of warranty registration and date of purchase may be required to verify warranty coverage. Any defective parts returned to TTI must be accompanied by a Return Goods Note. This form can be obtained by contacting Product Support on 1800 816 277 or emailing ProductSupport@tti.com.au.

Warranty Limitations

Warranty limitations are as follows:

1. There is no other express warranty. Any warranty that may be implied from this purchase including merchantability and fitness for purpose is hereby limited to the duration of this warranty and to the extent permitted by law. Any and all implied warranties are excluded.
2. TTI will not be liable for any incidental, consequential or special damages and/or expenses in connection with the purchase or use of this equipment, to the extent permitted by law.
3. Only the warranty expressed in this limited warranty shall apply and no dealer, distributor or individual is authorised to amend, modify, or extend this warranty in any way. Accordingly, additional statements, whether oral or written, do not constitute warranties by TTI, and should not be relied upon.



TranTank[®]
INTERNATIONAL



Scan to view our PDF
Handbook online

1800 816 277

sales@tti.com.au

PO Box 137, Nathalia, VIC, 3638

Murray Valley Hwy, Nathalia, VIC 3638

Proudly Built By:

Signature

Date

Quality Checked By:

Signature

Date

www.tti.com.au